

# PVP2460 – 6 Amp Bipolar Stepper Motor Drive Board



## Data Sheet

### Specification

#### Electrical

Motor Supply: +20 to +70 Vdc (+10% max.) smoothed unregulated.  
Logic Supply: +15 to +24 Vdc (+10% max.) smoothed unregulated.

Note: The motor and logic may share the same power supply up to +24V or provided a dropper resistor is fitted.

AUX Outputs:  
+12V regulated 50mA max.  
+5V regulated 50mA max.

Motor Drive Output:  
Bipolar chopped constant current with overload, short circuit between phases and thermal protection.  
6 Amps per phase max output-may be set lower by means of D.I.P. switch.  
Suitable for driving hybrid or permanent magnet motors with 4, 6 or 8 leads.  
The output stage will also be disabled if the logic supply is too low.

Control Inputs:  
CMOS Schmitt trigger inputs operating at +12V with 10kΩ pull ups and diode isolation.  
Logic 0 (low) - 0V to +2V or contact closure at 0V.  
Logic 1 (high) - +9V to +30V max. or open circuit.

Monitor Outputs:  
Open collector NPN transistor (ref. to 0V)  
Low level - +1 V max at 30mA max.  
High level - open circuit +24V dc max.

#### Mechanical & Physical

Card Size  
Eurocard format 220mm long x 100mm wide x 76mm high.

Weight : 950 grams approx.

Connector: 32 way PCB plug to DIN 41612 type D.

Printed Circuit Board: 1.6mm Glass fibre with solder mask and component identification.

Temperature: Operating range 0°C to +40°C max. ambient.  
Fan assisted cooling is recommended where high ambient temperatures persist.  
Thermal switch fitted as standard, operates at nominally 90 C.

**Figure 1 Control Input Options**

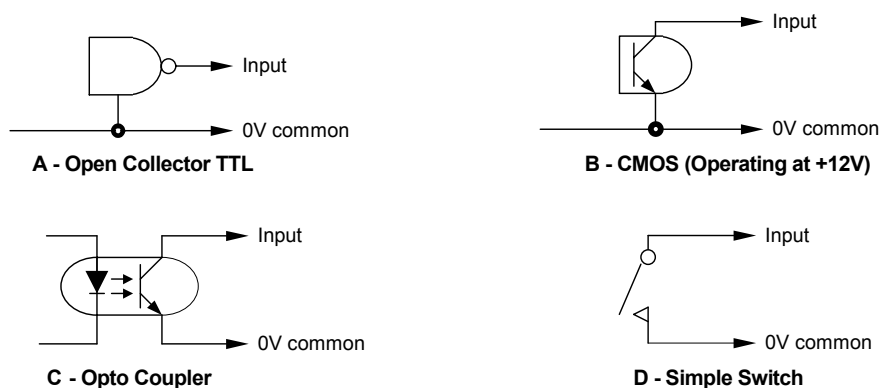

**Figure 2 Board Connections**

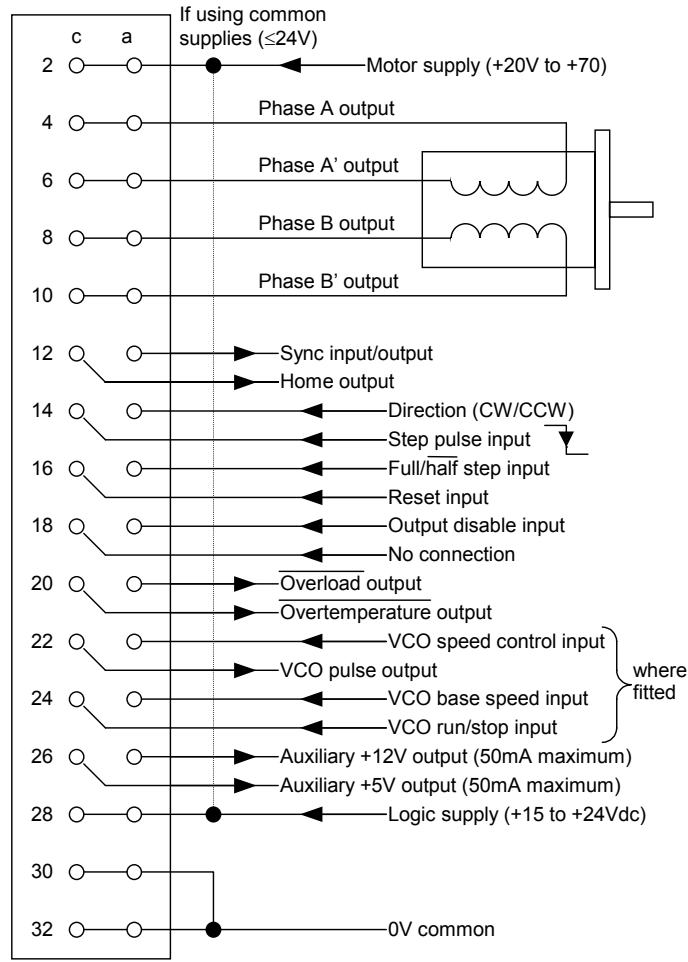

**Note** - If the on-board VCO has been fitted the VCO output may be connected directly to the step clock input.

**Board Connection Details**

Connector style DIN 41612 type D 32 way rows 'a' & 'c'.

<b>Pin</b>	<b>Function</b>	<b>Pin</b>	<b>Function</b>
2a & c	Motor supply input	20a	Overload output
4a & c	Motor phase output A	20c	Overtemp output
6a & c	Motor phase output A'	22a	V.C.O. Control Input
8a & c	Motor phase output B	22c	V.C.O. Pulse Input
10a & c	Motor phase output B'	24a	Base Speed Input
12a	Sync. Input/Output	24c	Stop/Run Input
12c	Home Phase Output	26a	Aux. + 12V Output
14a	CCW/CW Direction Control	26c	Aux +5V Output
14c	Clock Pulse Input	28a & c	Logic Supply Input
16a	Full/Half Step Control	30a & c	Supply Common 0V
16c	Reset Input	32a & c	Supply Common 0V
18a	Output Disable Input		
18c	No Connection		

where option is fitted

## Pin Functions

### **2a & c**

Motor supply input. Should be smoothed unregulated and between +20 and +70V max.

### **4, 6, 8 & 10a & c**

Motor Phase Outputs. Connect one phase between pins 4 & 6 and the other phase between 8 & 10. These outputs are short circuit protected between phases and overload protected to 0V

### **12a**

SYNC Input/Output. Used to synchronise drive cards in Multi-Axis systems to eliminate beat frequencies and ground plane problems.

### **12c**

Home Phase Output. This output is low when the unit is powered up and subsequently when the translator logic is in its initial state.

### **14a**

CCW/CW Direction Control. Connecting this pin to 0V will reverse the direction of shaft rotation.

### **14c**

Clock Pulse Input. The motor will increment one step on a high to low going impulse, which should remain active for at least 10µS. Maximum input frequency 20kHz.

### **16a**

Full/Half Step Control. Connecting this pin to 0V will select half step mode i.e. if the motor is normally 200 steps/rev. It will then produce 400 steps/rev. The output torque will normally be lower but resonance conditions are usually eliminated.

### **16c**

Reset Input. Connecting this pin to 0V will reset the internal logic to the Home Phase state (Home Phase output will be active).

### **18a**

Output Disable Input. Connecting this pin to 0V will disable the output stage thus allowing the motor to be rotated by hand if required.

**18c** No connection.

### **20a**

Overload Output. This output will go low, and remain latched, if an overload or short circuit is detected and will also disable the output stage. This circuit is reset by either temporarily removing the power or by taking the Reset input low.

### **20c**

Overtemp Output. This output will go low (nominally 90°C) and remain low for as long as the condition exists. There is also provision on board to link this function into the output Disable circuit if required. This output is also available on a 3-pin plug (PL2) on the board and may be used to actuate a miniature DC fan.

### **22a**

VCO Input. Applying a control voltage of between 0V and +12V will proportionally vary the output frequency of the internal V.C.O. (Optionally fitted).

### **22c**

VCO Output. A standard CMOS output (at +12V) of the internal V.C.O. This may be fed straight into the Clock Input (14c). (Optionally fitted).

### **24a**

Base Speed. Connect a variable resistor (10k to 1 meg) between this pin and 0V if base speed is required. Base speed is defined as a V.C.O. offset frequency which the motor will start and stop at when the Stop/Run input is operated. (Optionally fitted).

**24c** Stop/Run Input. Connecting this pin to 0V will enable the internal V.C.O.

**26a** Aux + 12V Output (50mA max) (available for external circuitry).

**26c** Aux +5V Output (50mA max) (available for external circuitry).

**28a & c** Logic Supply Input. Should be smoothed unregulated + 15V to +24Vdc maximum.

**30a & c** Supply Common 0V.

**32a & c** Supply Common 0V.





## Starting (base) and running speed control

The on-board oscillator can be arranged to start at a fixed frequency (thus a fixed motor speed) and then ramp up to a final value (the running motor speed). This facility is available to start the motor within its pull-in performance region and then accelerate the motor through so that it can operate within the pull-out mode. On switch-off the motor decelerates automatically.

Three parameters need to be determined for any application:

- A. The starting speed: this should be below the pull-in speed for the motor (with any additional load).
- B. The running (final) speed: this should be within the pull-out capability of the motor (with any additional load).
- C. The acceleration and deceleration rate between starting and running speeds: this is limited by the motor capability to accelerate through its own (plus any load) inertia.

**Figure 5. Oscillator Controls (External)**

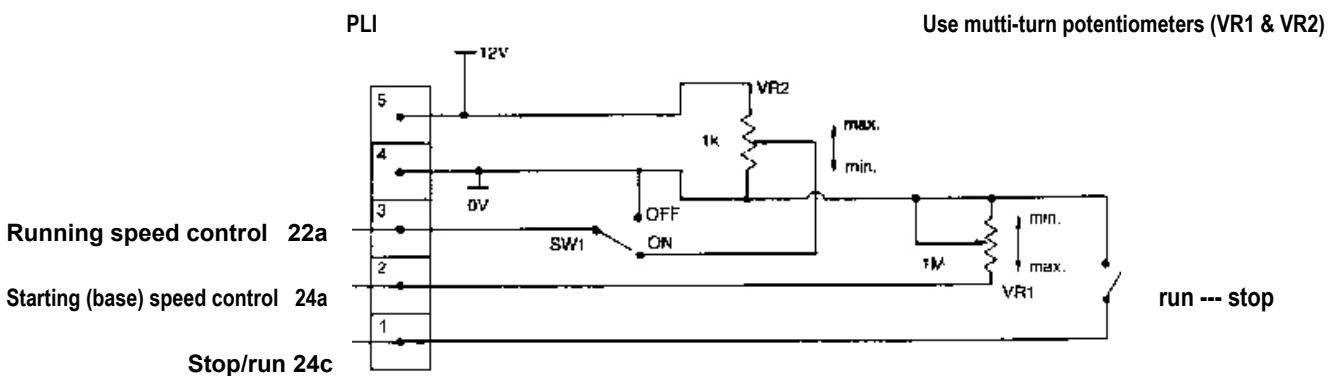

# Motor Speed-Ramping Characteristic

Figure 6.

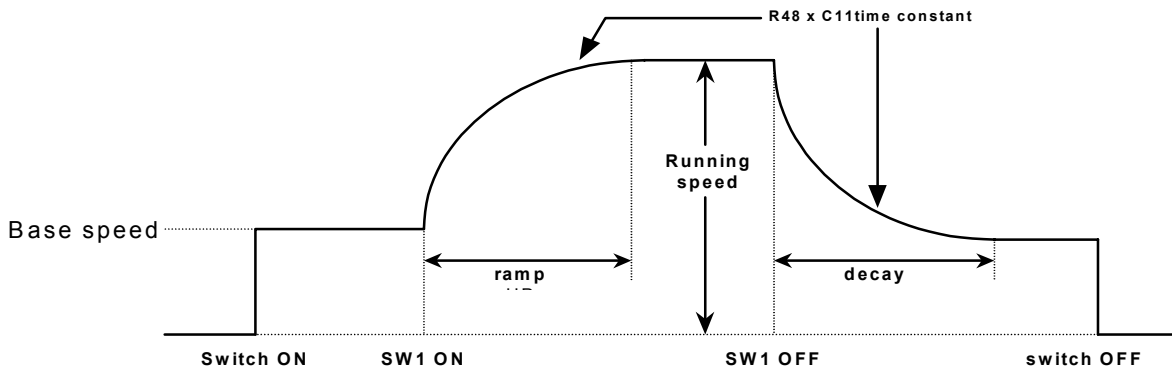

**Note:** Oscillator frequency corresponds directly to motor speed in steps/s or half steps/s depending on motor drive mode.

**For a 1.8° stepper motor**

$$\text{Speeds in revs/min} = \frac{60}{200} \times \text{speed in steps/s}$$

$$\text{or } \frac{60}{400} \times \text{speed in half steps/s}$$

**For a 7.5° stepper motor**

$$\text{speed in revs/min} = \frac{60}{48} \times \text{speed in steps/s}$$

$$\text{or } \frac{60}{96} \times \text{speed in half steps/s}$$

## Oscillator Frequency Setting

Recommended component values

VR1	0-1 MΩ	VR2	1 kΩ
R52	10kΩ - 1MΩ	C12	greater than 100pf

Determine the base frequency and maximum running frequency. Using Fig. 7 and the base frequency value choose a value for C12 and VR1. Calculate the ratio max. running frequency/base frequency to determine the ratio of :-

$$\frac{VR1 + R49(\text{fixed at } 10k\Omega)}{R52} \quad \text{and thus using Fig. 8 establish the required value for R52.}$$

Base frequency (R52 = ∞VR2 = min.)

Max. running frequency/base frequency

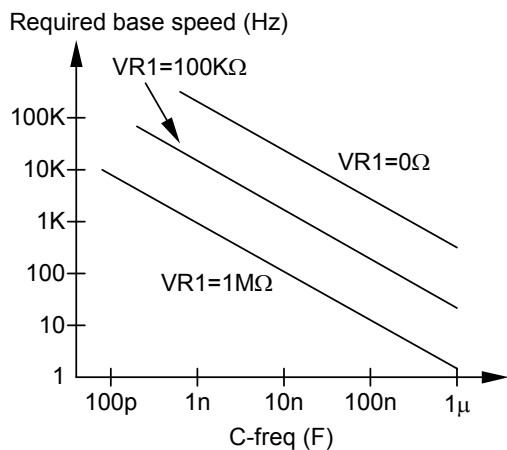

Figure 7.

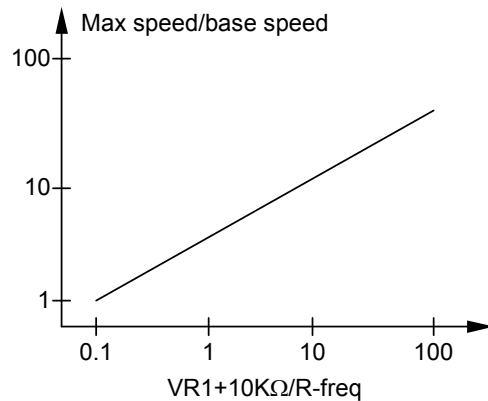
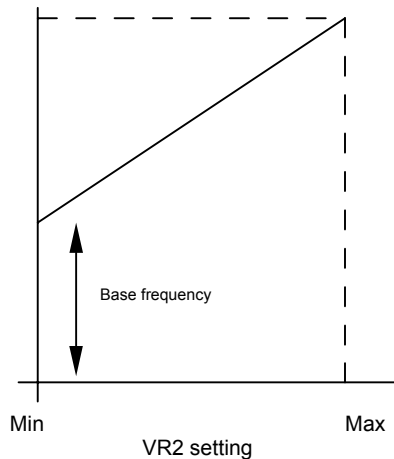

Figure 8.

Once all component values are established and assembled the oscillator frequency range is as shown in Fig. 9. If SW1 is OFF the oscillator runs at base frequency. When SW1 is On the oscillator builds up (at a rate depending on R48 x C11 time constant) to a frequency determined by VR2 setting.

Max running frequency



**Figure 9.**

#### Installation - General Notes

1. **SERIOUS DAMAGE WILL OCCUR** if a motor lead becomes disconnected whilst the drive is energised.
2. The drive board should always be mounted such that the heatsink fins are vertical i.e. board on edge, and adequate clearance be given top and bottom i.e. 25mm minimum. When rack mounting the board there should be at least a 15mm clearance between the heatsink and an adjacent board.
3. When using the drive at high ambient temperatures or at slow speeds/standstill at maximum current and voltage it will prove advantageous to force cool the heatsink.
4. Motor and power supply connections should be made in at least 32/0.2mm wire due to the high peak currents flowing, all other wiring can be 7/0.2mm.
5. No damage will occur, but the Full step/Half step input (pin 16a) should be connected as required before the drive is energised.
6. **SERIOUS DAMAGE CAN OCCUR** if this board is plugged in or out with power still applied or the power supply not fully discharged. Once the power supply has been switched off **WAIT AT LEAST 30 SECONDS** before unplugging the board. When using Power Supplies other than those manufactured by Mclennan please ensure that a suitable discharge (bleed) resistor (i.e. 2K2 at 6W) is fitted across the Motor Supply rail (pins 2ac to 32ac). This will help prevent any residual voltage from damaging the Stepper Drive if the board is plugged in or out prematurely.

**Mclennan Servo Supplies Ltd.**  
**Unit 1, The Royston Centre,**  
**Lynchford Road,**  
**Ash Vale,**  
**Surrey,**  
**GU12 5PQ**  
**UK**



Telephone:	+44 (0)8707 700 700
FAX:	+44 (0)8707 700 699
Sales EMAIL:	<a href="mailto:sales@mclennan.co.uk">sales@mclennan.co.uk</a>
Technical support EMAIL:	<a href="mailto:tech@mclennan.co.uk">tech@mclennan.co.uk</a>
Web:	<a href="http://www.mclennan.co.uk">www.mclennan.co.uk</a>

**Mclennan Servo Supplies Ltd reserves the right to update the data used in this manual in line with product development without prior notice**