

# PVP192

## 2 Amp Bipolar Stepper Motor Drive Module

---

### PLEASE READ THESE NOTES BEFORE INSTALLATION:-

1. SERIOUS DAMAGE CAN OCCUR if a motor lead becomes disconnected whilst the drive module has power applied.
  2. SERIOUS DAMAGE CAN OCCUR if any wiring is attempted whilst the power is still applied or the power supply is not fully discharged. Once the power supply has been switched off WAIT AT LEAST 30 SECONDS and ensure that the GREEN LED (LED 2) is off before proceeding.
  3. When using this module at higher ambient temperatures ( $>30^{\circ}\text{C}$ ) or at motor currents of  $>1$  Amp per phase and motor rail voltages of  $>24$  Vdc or when using fast acceleration/deceleration rates, additional heatsinking will be required. We recommend the use of a heatsink with a thermal coefficient of  $2^{\circ}\text{C/W}$  or better.
  4. No damage will occur but we recommend the FULL/HALF step mode input should be connected as required before power is applied to the module.
  5. Motor and power supply connections should be made with at least 16/0.2mm cable due to the high peak currents flowing. All signal wiring can be 7/0.2mm, and we recommend the use of twisted pairs for long cable runs ( $>3\text{m}$ ) or electrically noisy environments.
- 

### SPECIFICATIONS

#### Electrical

Motor supply: +12 to +36Vdc maximum, smoothed unregulated

Logic supply: +12 to +36Vdc maximum, smoothed unregulated

#### Notes:

- a. The motor and logic may share the same power supply.
- b. Logic 0V and Motor 0V are connected internally. Use Motor 0V if only one connection is preferred.
- c. The modules chassis is electrically isolated from the 0V connection.

#### Motor Drive Output:

Bipolar chopped constant current, a 3 Amp (T) on-board fuse (FS1) helps protect against short circuits to 0V.

The motor output current is adjustable up to 2 Amps\* per phase maximum by an on-board potentiometer (RV1). The module is supplied factory set at 1 Amp per phase.

An over temperature trip is fitted to the module which triggers at approx.  $70^{\circ}\text{C}$ , this device disables the motor output and the RED LED (LED 1) will illuminate. The thermal trip automatically resets when the module has become cooler\*, the motor output is then re-enabled.

\* Please read NOTE 3



## Pin Functions

TB1-1 Logic supply input, +12 to +36Vdc maximum, smoothed unregulated.

TB1-2 Logic supply common 0V.

TB1-3 +anode ) Standby current select. When the opto diode conducts, motor output current  
TB1-4 -cathode) is reduced to approx 30% of that set by RV1. This can be used to reduce dissipation in the motor at standstill.

TB1-5 +anode ) Output enable. When the opto diode conducts, the motor output stage is  
TB1-6 -cathode) enabled and power is applied to the motor.

TB1-7 +anode ) Full/Half step mode. When the opto diode conducts, half step mode is  
TB1-8 -cathode) enabled **i.e.** if the motors normal resolution is 200 steps /rev, it will then produce 400 steps/rev. This function can reduce motor resonance and normally extend the usable speed range.

TB1-9 +anode ) Direction control. When the opto diode conducts the direction of shaft  
TB1-10 -cathode) will reverse. Initial CW or CCW rotation is dependent on motor wiring.

TB1-11 +anode ) Clock or Pulse input. When the opto diode makes a transition from  
TB1-12 -cathode) not conducting to conducting the motor will increment one step. The maximum input frequency is 10kHz and the minimum pulse width should be 50µS, although a square wave with a 50/50 mark/space ratio is preferable.

TB2-1 Motor Output A1 ) One motor phase should be connected across these two  
TB2-2 Motor Output A2 ) terminals.

TB2-3 Motor supply common 0V.

TB2-4 Motor supply input, +12 to +36Vdc maximum, smoothed unregulated.

TB2-5 Motor Output B1 ) One motor phase should be connected across these two  
TB2-6 Motor Output B2 ) terminals.

## Setting the motor output current

This is achieved by adjusting the potentiometer RV1. Connect a high impedance multi meter, set at 2Vdc FSD, across TP2 (-ve) and TP1 (+ve). The module is factory set at 1 Amp per phase, such that a reading of approx 0.47 Volts should be observed, therefore the following scaling factor can be used:-

$$V_{TP1-2} = \text{Required current per phase} \times 0.47$$

i.e. A reading of 0.94 Volts = 2 Amps per phase, and 0.235 Volts = 0.5 Amps per phase

## Connecting stepper motors and motor selection

The flexibility of the on-board motor current setting and wide operating voltage of the module allows an extensive range of motors to be utilised.

The best high speed torque performance will be obtained using a motor with a high current rating and low winding inductance, although low speed torque may suffer and motor resonance occur (coils in parallel). Conversely, for high torque low speed operation a motor with a higher winding resistance and inductance should be used (coils in series).

To prevent excessive dissipation in the motor, and possible damage, the following guidelines should be used.

When using 8 lead motors with coils in parallel the motor current should be set no greater than:-

$$\text{Motor current per phase rating} \times \sqrt{2}$$

When using 6 or 8 lead motors with coils in series the motor current should be set no greater than:-

$$\frac{\text{Motor current per phase rating}}{\sqrt{2}}$$

Motors with 4 leads have a bipolar rating and can be used according to the manufacturers specifications.

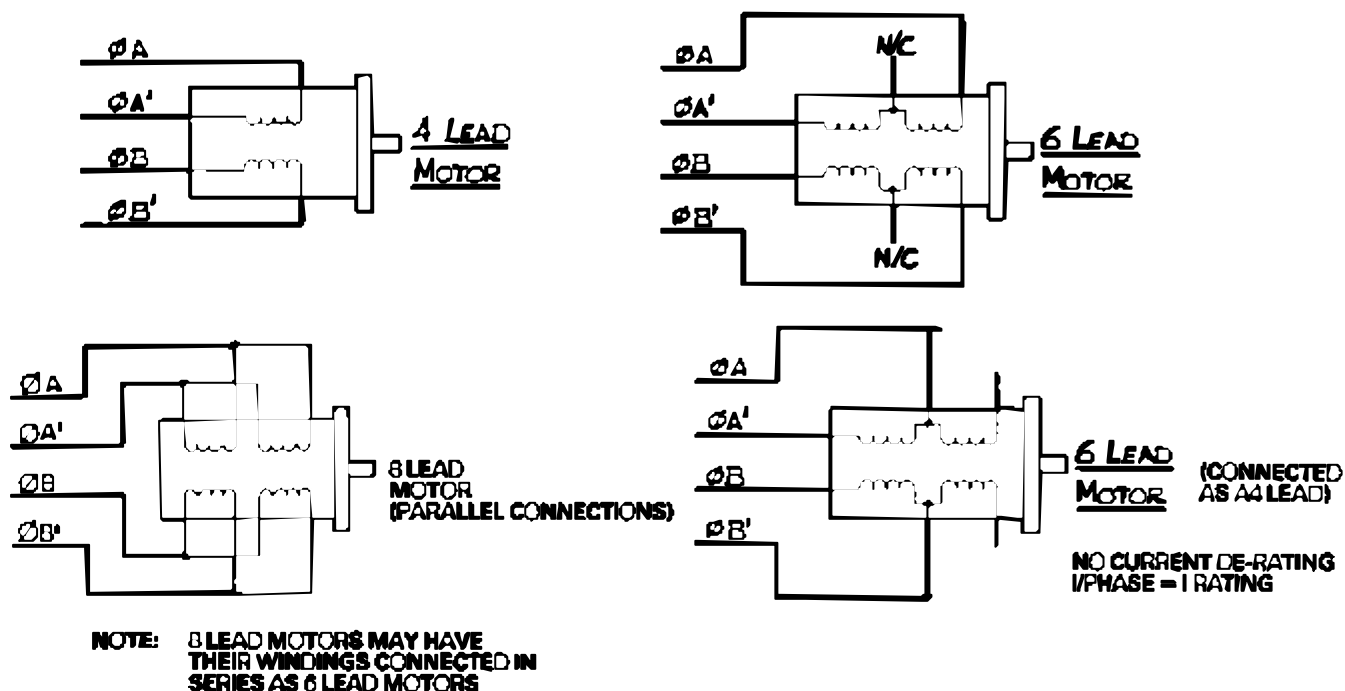

## Mclennan Servo Supplies

Unit 1, The Royston Centre, Lynchford Lane,  
Ash Vale, Surrey. UK GU12 5PQ  
Tel: +44 (0) 8707 700 700  
Fax: +44 (0) 8707 700 699  
Email: sales@mclennan.co.uk  
Website: <http://www.alzanti.com>

# 3rd ANGLE PROJECTION



METRIC  
IMPERIAL

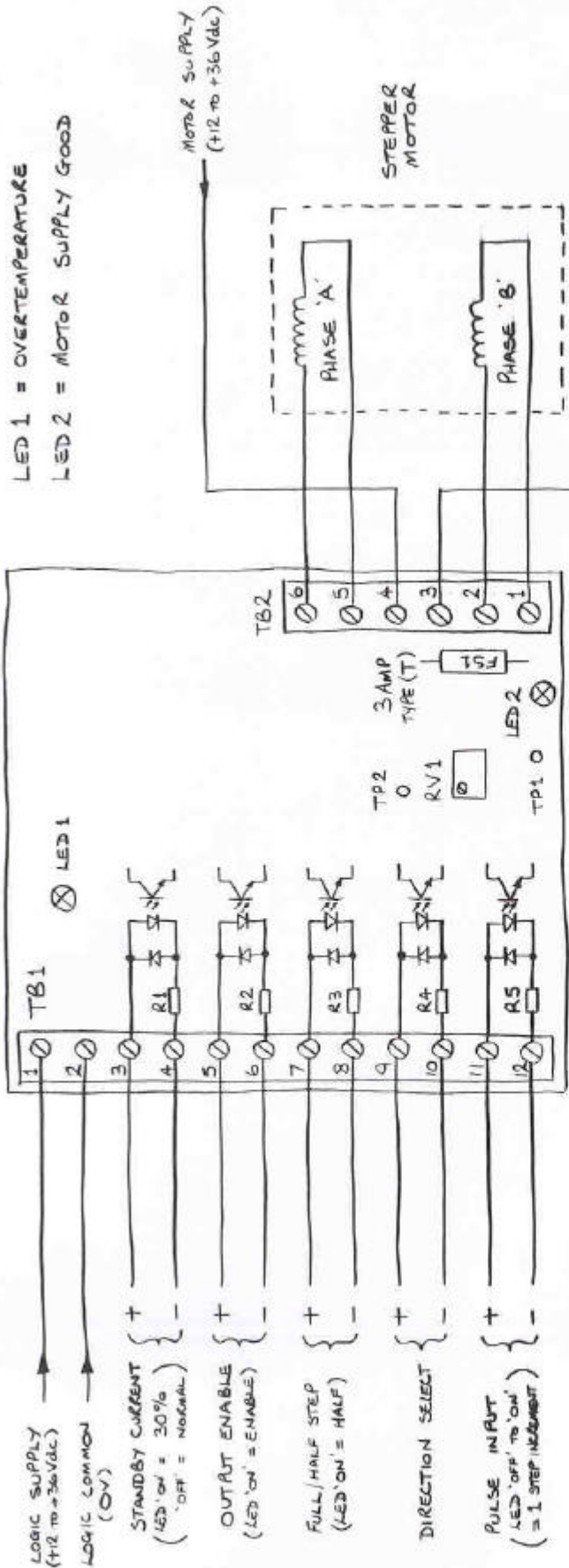

LED 1 = OVERTEMPERATURE  
LED 2 = MOTOR SUPPLY GOOD

MOTOR SUPPLY  
(+12 to +36Vdc)

STEPPER  
MOTOR

RV1 SETS MOTOR OUTPUT CURRENT  
SCALE VOLTAGE =  
OUTPUT CURRENT X 0.47  
WHEN MEASURED FROM TP2 TO TP1  
I.E. 0.94V = 2A / PHASE

R1 THROUGH R5 ARE 220R FOR  
+5V LOGIC INPUT OPERATION.

FOR OTHER VOLTAGES USE :-  
$$R = \frac{V_{SUPPLY} - 1.5}{0.015}$$

12V = 680R  
24V = 1K5

DRAWN P.W.	ALZANTI LIMITED		MATERIAL	FINISH
	DIMENSIONS IN MILLIMETRES SCALE			
APPROVED	TITLE			TOLERANCES (UNLESS STATED)
	PVP 192 2AMP BIPOLAR STEPPER DRIVE			TWO DECIMAL PLACES ±0.15mm.
	— CONNECTION DETAILS			ONE DECIMAL PLACE ±0.3mm.
				WHOLE FIGURES ±0.5mm.
				ANGLES ±0°30'
FIRST DRAWN	1	8/3/99		DRAWING NUMBER
MOD. No.				PVP 192 - 0002D
				ISSUE DATE
				© 1999
				3